

STOLL



**Valid from
18.05.2023**

**PRICE LIST
2023**

GENERAL NOTES ON FRONT LOADER PRODUCTS:

„Front loaders without lowering protection do not meet the requirements of DIN EN 12525 in regard to the presence of persons in the danger area of the loader with raised load.“

„Front loaders without lowering choke do not meet the requirements for transport of persons; transport of persons requires the EU Typee testing according to the machinery directive 2006/42/EC.“

„Please make sure to observe the correct allocation of the lifting arm to the console installed on the tractor; information in the installation instructions under number (....)“

„Please note that you as dealer are obligated to verify the manufacturer's specifications on front loader use before selling and installing the front loader for the customer. Wilhelm Stoll Maschinenfabrik GmbH does not know and has no access to the respective current manufacturer's specifications. In the event of possible restrictions on the part of the tractor manufacturer regarding the front loader attachment and its use, e.g. road approval, warranty or others, the end customer must be informed of this in advance in writing. Any claims arising from non-compliance with the aforementioned duty to provide information and from non-compliance with the manufacturer's specifications are excluded.“

CONTENTS.

Price overview – ProfiLine Next Generation, Solid, CompactLine	4 - 5
Accessories – ProfiLine Next Generation, Solid, CompactLine	6
Package prices	7 - 9
ProfiLine Next Generation, Solid – Hydraulic controls and accessories	10 - 11
Hydro-Fix – Rapid hydraulic connection	12 - 13
Work quickly, safely and comfortably – with STOLL accessories	14 - 16
Color Edition	17
ProfiLine – The Next Generation	18
Solid – The all-rounder	19
CompactLine – Smart power package	20
Tools	21 - 41
Recommended tool width	42 - 43
Your contacts at STOLL	44
General	45

With the publication of this price list all previous price lists are rendered invalid.

PRICE OVERVIEW.

PROFILINE NEXT GENERATION

mech. parallel linkage	Fixtures	FZ 36-20	FZ 36-24	FZ 39-23	FZ 39-27	FZ 39-31	FZ 41-25	FZ 41-29	FZ 41-33	FZ 43-27	FZ 43-30	FZ 43-34	FZ 46-26	FZ 46-29	FZ 46-33	FZ 48-33	FZ 48-37	FZ 48-42
		\$10,785	\$11,085	\$11,385	\$11,835	\$12,135	\$12,585	\$13,035	\$13,485	\$14,235	\$14,535	\$14,835	\$16,485	\$16,935	\$17,235	\$19,485	\$19,935	\$20,385
A	\$3,250	\$14,035	\$14,335	\$14,635	\$15,085	\$15,385	\$15,835	\$16,285	\$16,735	\$17,485	\$17,785	\$18,085	\$19,735	\$20,185	\$20,485	\$22,735	\$23,185	\$23,635
B	\$3,790	\$14,575	\$14,875	\$15,175	\$15,625	\$15,925	\$16,375	\$16,825	\$17,275	\$18,025	\$18,325	\$18,625	\$20,275	\$20,725	\$21,025	\$23,275	\$23,725	\$24,175
C	\$4,390	\$15,175	\$15,475	\$15,775	\$16,225	\$16,525	\$16,975	\$17,425	\$17,875	\$18,625	\$18,925	\$19,225	\$20,875	\$21,325	\$21,625	\$23,875	\$24,325	\$24,775
D	\$5,320	\$16,105	\$16,405	\$16,705	\$17,155	\$17,455	\$17,905	\$18,355	\$18,805	\$19,555	\$19,855	\$20,155	\$21,805	\$22,255	\$22,555	\$24,805	\$25,255	\$25,705

without parallel linkage	Fixtures	FS 36-24	FS 39-27	FS 39-31	FS 41-33	FS 43-34
		\$10,335	\$10,635	\$11,085	\$12,435	\$13,335
A	\$3,250	\$13,585	\$13,885	\$14,335	\$15,685	\$16,585
B	\$3,790	\$14,125	\$14,425	\$14,875	\$16,225	\$17,125
C	\$4,390	\$14,725	\$15,025	\$15,475	\$16,825	\$17,725
D	\$5,320	\$15,655	\$15,955	\$16,405	\$17,755	\$18,655

You can find categories of tractor attachments via our website price configurator and in the download area of our website from 18.05.2023!

Concentrated power strength
in numbers for you.

SOLID

P = parallel linkage H = without parallel linkage	Fixtures	28-14 P	30-16 P	35-18 P	38-20 P	40-22 P	30-16 H	35-18 H	38-20 H
		\$7,035	\$7,185	\$7,635	\$8,085	\$9,285	\$6,735	\$7,185	\$7,635
A	\$3,250	\$10,285	\$10,435	\$10,885	\$11,335	\$12,535	\$9,985	\$10,435	\$10,885
B	\$3,790	\$10,825	\$10,975	\$11,425	\$11,875	\$13,075	\$10,525	\$10,975	\$11,425
C	\$4,390	\$11,425	\$11,575	\$12,025	\$12,475	\$13,675	\$11,125	\$11,575	\$12,025
D	\$5,320	\$12,355	\$12,505	\$12,955	\$13,405	\$14,605	\$12,055	\$12,505	\$12,955

COMPACTLINE

mech. parallel linkage	Fixtures	150 P	250 P	350 P	450 P	550 P
		\$5,995	\$6,955	\$7,405	\$7,975	\$8,335
A	\$1,710	\$7,705	\$8,665	\$9,115	\$9,685	\$10,045
B	\$2,070	\$8,065	\$9,025	\$9,475	\$10,045	\$10,405
C	\$2,490	\$8,485	\$9,445	\$9,895	\$10,465	\$10,825
D	\$2,805	\$8,800	\$9,760	\$10,210	\$10,780	\$11,140

ACCESSORIES.

PROFILINE NEXT GENERATION

PROFILINE FZ/FS	Price (excl. VAT)	CONTROL CIRCUITS	Price (excl. VAT)
Hydro-fix cpl.	\$1,020	Base Control Universal	\$2,070
3rd control circuit or 4th control circuit	\$705	Base Control	\$2,530
Tool-fix cpl.	\$790	Pro Control 3 key*	\$5,055
1/2 boom-end tool-fix	\$525	Pro Control 5 key*	\$5,290
Comfort-Drive/incl. electr. activation/deactivation	\$915 / \$1,635	Trac Control	\$520
Hydr. attachment locking	\$1,110	Tubing set	\$600
RTL function FZ	\$1,590		
Real ³ function	\$2,020		
Lowering safeguard**	\$1,360		
**Additional equipment on both sides (kit)	\$690		
Work lights (only FZ)	\$1,270		

*Pro Control must not be used in combination with front loaders without mechanical parallel linkage.

SOLID

SOLID	Price (excl. VAT)
Hydro-fix cpl.	\$1,020
3rd control circuit or 4th control circuit*	\$610
Comfort-Drive	\$720
Lowering safeguard**	\$1,360
**Additional equipment on both sides (kit)	\$690

*4th control circuit can only be ordered in combination with 3rd control circuit.

SPECIAL PAINT JOB FZ/FS/SOLID

Price (excl. VAT)	
For all current tractor makes	\$360

OPTIONAL EQUIPMENT (see tractor list)

Price (excl. VAT)	
Rear axle support 0-option	\$705

COMPACTLINE

COMPACTLINE	Price (excl. VAT)	CONTROL CIRCUITS	Price (excl. VAT)
Tool-fix cpl.	\$850	Base Control Direct	\$1,360
Hydro-fix cpl.	\$1,105	Base Control	\$2,320
3rd control circuit	\$985	Tubing set	\$655
Comfort drive	\$1,125		
Lowering safeguard**	\$1,360		
**Additional equipment on both sides (kit)	\$690		

TRANSPORT COSTS FZ/FS/SOLID/FC

Price (excl. VAT)	
Per loader/boom	Ex works
Fixtures per part	Ex works
Per attachment	Ex works
From 5 attachments	freight prepaid

PACKAGE STANDARD.

ACCESSORIES PACKAGE: PROFILINE NEXT GENERATION AND SOLID

incl. tubing set, 3rd control circuit, Comfort drive mech. + Hydro-fix cpl.

PROFILINE NEXT GENERATION

Cat. Fixtures	Fixtures	FZ 36-20	FZ 36-24	FZ 39-23	FZ 39-27	FZ 39-31	FZ 41-25	FZ 41-29	FZ 41-33	FZ 43-27	FZ 43-30	FZ 43-34	FZ 46-26	FZ 46-29	FZ 46-33	FZ 48-33	FZ 48-37	FZ 48-42
A		\$17,275	\$17,575	\$17,875	\$18,325	\$18,625	\$19,075	\$19,525	\$19,975	\$20,725	\$21,025	\$21,325	\$22,975	\$23,425	\$23,725	\$25,975	\$26,425	\$26,875
B		\$17,815	\$18,115	\$18,415	\$18,865	\$19,165	\$19,615	\$20,065	\$20,515	\$21,265	\$21,565	\$21,865	\$23,515	\$23,965	\$24,265	\$26,515	\$26,965	\$27,415
C		\$18,415	\$18,715	\$19,015	\$19,465	\$19,765	\$20,215	\$20,665	\$21,115	\$21,865	\$22,165	\$22,465	\$24,115	\$24,565	\$24,865	\$27,115	\$27,565	\$28,015
D		\$19,345	\$19,645	\$19,945	\$20,395	\$20,695	\$21,145	\$21,595	\$22,045	\$22,795	\$23,095	\$23,395	\$25,045	\$25,495	\$25,795	\$28,045	\$28,495	\$28,945

SOLID

Cat. Fixtures	Fixtures	FS 36-24	FS 39-27	FS 39-31	FS 41-33	FS 43-34
A		\$16,825	\$17,125	\$17,575	\$18,925	\$19,825
B		\$17,365	\$17,665	\$18,115	\$19,465	\$20,365
C		\$17,965	\$18,265	\$18,715	\$20,065	\$20,965
D		\$18,895	\$19,195	\$19,645	\$20,995	\$21,895

Cat. Fixtures	Fixtures	28-14 P	30-16 P	35-18 P	38-20 P	40-22 P	30-16 H	35-18 H	38-20 H
A		\$13,235	\$13,385	\$13,835	\$14,285	\$15,485	\$12,935	\$13,385	\$13,835
B		\$13,775	\$13,925	\$14,375	\$14,825	\$16,025	\$13,475	\$13,925	\$14,375
C		\$14,375	\$14,525	\$14,975	\$15,425	\$16,625	\$14,075	\$14,525	\$14,975
D		\$15,305	\$15,455	\$15,905	\$16,355	\$17,555	\$15,005	\$15,455	\$15,905

PACKAGE BASIC.

ACCESSORIES PACKAGE: PROFILINE NEXT GENERATION AND SOLID

incl. Base Control, 3rd control circuit, Comfort drive mech. + Hydro-fix cpl.

PROFILINE NEXT GENERATION

Cat. Fixtures	Fixtures	FZ 36-20	FZ 36-24	FZ 39-23	FZ 39-27	FZ 39-31	FZ 41-25	FZ 41-29	FZ 41-33	FZ 43-27	FZ 43-30	FZ 43-34	FZ 46-26	FZ 46-29	FZ 46-33	FZ 48-33	FZ 48-37	FZ 48-42
A		\$19,205	\$19,505	\$19,805	\$20,255	\$20,555	\$21,005	\$21,455	\$21,905	\$22,655	\$22,955	\$23,255	\$24,905	\$25,355	\$25,655	\$27,905	\$28,355	\$28,805
B		\$19,745	\$20,045	\$20,345	\$20,795	\$21,095	\$21,545	\$21,995	\$22,445	\$23,195	\$23,495	\$23,795	\$25,445	\$25,895	\$26,195	\$28,445	\$28,895	\$29,345
C		\$20,345	\$20,645	\$20,945	\$21,395	\$21,695	\$22,145	\$22,595	\$23,045	\$23,795	\$24,095	\$24,395	\$26,045	\$26,495	\$26,795	\$29,045	\$29,495	\$29,945
D		\$21,275	\$21,575	\$21,875	\$22,325	\$22,625	\$23,075	\$23,525	\$23,975	\$24,725	\$25,025	\$25,325	\$26,975	\$27,425	\$27,725	\$29,975	\$30,425	\$30,875

SOLID

Cat. Fixtures	Fixtures	FS 36-24	FS 39-27	FS 39-31	FS 41-33	FS 43-34
A		\$18,755	\$19,055	\$19,505	\$20,855	\$21,755
B		\$19,295	\$19,595	\$20,045	\$21,395	\$22,295
C		\$19,895	\$20,195	\$20,645	\$21,995	\$22,895
D		\$20,825	\$21,125	\$21,575	\$22,925	\$23,825

Cat. Fixtures	Fixtures	28-14 P	30-16 P	35-18 P	38-20 P	40-22 P	30-16 H	35-18 H	38-20 H
A		\$15,165	\$15,315	\$15,765	\$16,215	\$17,415	\$14,865	\$15,315	\$15,765
B		\$15,705	\$15,855	\$16,305	\$16,755	\$17,955	\$15,405	\$15,855	\$16,305
C		\$16,305	\$16,455	\$16,905	\$17,355	\$18,555	\$16,005	\$16,455	\$16,905
D		\$17,235	\$17,385	\$17,835	\$18,285	\$19,485	\$16,935	\$17,385	\$17,835

You can find categories of tractor attachments via our website price configurator and in the download area of our website from 18.05.2023!

PACKAGE PRO.

ACCESSORIES PACKAGE: PROFILINE NEXT GENERATION AND SOLID

incl. Pro Control, 3rd control circuit, Comfort drive mech. + Hydro-fix cpl.

PROFILINE NEXT GENERATION

Cat. Fixtures	Fixtures	FZ 36-20	FZ 36-24	FZ 39-23	FZ 39-27	FZ 39-31	FZ 41-25	FZ 41-29	FZ 41-33	FZ 43-27	FZ 43-30	FZ 43-34	FZ 46-26	FZ 46-29	FZ 46-33	FZ 48-33	FZ 48-37	FZ 48-42
A		\$21,730	\$22,030	\$22,330	\$22,780	\$23,080	\$23,530	\$23,980	\$24,430	\$25,180	\$25,480	\$25,780	\$27,430	\$27,880	\$28,180	\$30,430	\$30,880	\$31,330
B		\$22,270	\$22,570	\$22,870	\$23,320	\$23,620	\$24,070	\$24,520	\$24,970	\$25,720	\$26,020	\$26,320	\$27,970	\$28,420	\$28,720	\$30,970	\$31,420	\$31,870
C		\$22,870	\$23,170	\$23,470	\$23,920	\$24,220	\$24,670	\$25,120	\$25,570	\$26,320	\$26,620	\$26,920	\$28,570	\$29,020	\$29,320	\$31,570	\$32,020	\$32,470
D		\$23,800	\$24,100	\$24,400	\$24,850	\$25,150	\$25,600	\$26,050	\$26,500	\$27,250	\$27,550	\$27,850	\$29,500	\$29,950	\$30,250	\$32,500	\$32,950	\$33,400

SOLID

Cat. Fixtures	Fixtures	FS 36-24	FS 39-27	FS 39-31	FS 41-33	FS 43-34
A		\$21,280	\$21,580	\$22,030	\$23,380	\$24,280
B		\$21,820	\$22,120	\$22,570	\$23,920	\$24,820
C		\$22,420	\$22,720	\$23,170	\$24,520	\$25,420
D		\$23,350	\$23,650	\$24,100	\$25,450	\$26,350

Cat. Fixtures	Fixtures	28-14 P	30-16 P	35-18 P	38-20 P	40-22 P	30-16 H	35-18 H	38-20 H
A		\$17,690	\$17,840	\$18,290	\$18,740	\$19,940	\$17,390	\$17,840	\$18,290
B		\$18,230	\$18,380	\$18,830	\$19,280	\$20,480	\$17,930	\$18,380	\$18,830
C		\$18,830	\$18,980	\$19,430	\$19,880	\$21,080	\$18,530	\$18,980	\$19,430
D		\$19,760	\$19,910	\$20,360	\$20,810	\$22,010	\$19,460	\$19,910	\$20,360

You can find categories of tractor attachments via our website price configurator and in the download area of our website from 18.05.2023!

PROFILINE NEXT GENERATION. SOLID. HYDRAULIC CONTROL AND ACCESSORIES.

HIGH COMFORT AND EASY OPERATION WITH HYDRAULIC CONTROLS.

BASE CONTROL		Price (excl. VAT)
 <ul style="list-style-type: none"> ✓ High operating comfort with safe, exact loader guidance. ✓ Integrated push-button switch for additional functions. ✓ Five basic functions: lift, lower, scoop, dump, float position. ✓ Locking function for road driving. 	Base control (adapted)	\$2,530
	Assembly kit (universal) (without hydraulic tubing and cab mount)	\$2,070

PRO CONTROL		Price (excl. VAT)
 <ul style="list-style-type: none"> ✓ Simple, proportional loader operation. ✓ Six basic functions: lift, lower, scoop, dump, float position, float position for tools. ✓ Three additional functions: rapid emptying, 3rd/4th control circuit, locking function for road driving. ✓ Additionally possible: Hydro-Lock, Comfort drive and reversing. 	Pro Control (ECO-Pro system for OC, OCLS, CCLS)	\$5,055
	5-button joystick optional (additional cost)	\$235

DOUBLE LOCKING		Price (excl. VAT)
	<ul style="list-style-type: none"> ✓ Standard for size 5 + 6 (see p. 18). ✓ Optional for size 4 (see p. 18). ✓ For heavy work loads. 	<p>more budget \$840</p>

TRAC CONTROL		Price (excl. VAT)
	<ul style="list-style-type: none"> ✓ Five basic functions: lift, lower, scoop, dump, float position. ✓ The ergonomic Trac Control replaces the original push-button-less tractor joystick for electronic functions. 	<p>Trac Control (STOLL joystick) for tractor's own proportional single-lever control device \$525</p>

TUBING SET HYDRAULICS		Price (excl. VAT)
	<ul style="list-style-type: none"> ✓ Used when tractor has own control devices available. ✓ Individual adaptation to the tractor in question. ⚠ A double function and/or an external actuation must be rendered impossible by a correct installation. 	<p>\$600</p>

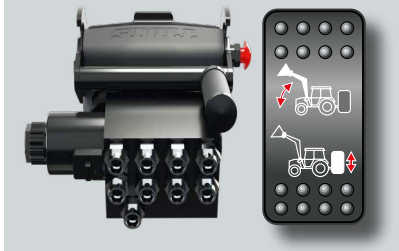
COMFORT-HYDRAULICS		Price (excl. VAT)
	<ul style="list-style-type: none"> ✓ Pre-selector switch to activate front loader or rear hydraulics. ✓ Prevents any possible double activation of front loader and rear hydraulics. ⚠ The possibility of the system being activated externally must be eliminated by a correct installation. 	<p>\$1,635</p>

The single-lever control devices on offer are exclusively intended for use with agricultural or forestry tractors for operation of STOLL front loaders.

Non-binding price recommendation in € excluding VAT.

HYDRO-FIX. RAPID HYDRAULIC CONNECTION.

**ALL HYDRAULIC LINES ARE RAPIDLY CONNECTED
AND RELEASED – WITH JUST ONE HANDLE.**

STOLL HYDRO-FIX – RECTANGULAR / 4X COUPLING		Type	Order No.	Price (excl. VAT)
	HYDRO-FIX cpl. Stoll SLC	FZ/FS	3645170	\$1,020
	HYDRO-FIX cpl. w/o Stoll SLC	FZ/FS	3645180	\$1,020
	Plug plate (above)	FZ/FS	3645190	\$430
	Equip. second tractor Stoll SLC	FZ/FS	3609870	\$595
	Equip. second tractor w/o Stoll SLC	FZ/FS	3609860	\$595
* able to couple under high pressure				

STOLL HYDRO-FIX – RECTANGULAR / 4X COUPLING		Type	Order No.	Price (excl. VAT)
	HYDRO-FIX cpl.	FZ/FS/S	3645300	\$1,020
	Plug plate (above)	FZ/FS/S	3645190	\$430
	Equip. Second tractor	FZ/FS/S	3537370	\$595
	* able to couple under high pressure			

STOLL HYDRO-FIX – RECTANGULAR W. ELECTRIC 8-PIN PLUG		Type	Order No.	Price (excl. VAT)
	HYDRO-FIX cpl. Stoll SLC	FZ/FS/S	3645200	\$1,300
	HYDRO-FIX cpl. w/o Stoll SLC	FZ/FS/S	3645220	\$1,300
	Plug plate (above)	FZ/FS/S	3645230	\$705
	Equip. for second tractor Stoll SLC	FZ/FS/S	3618680	\$595
	Equip. for second tractor w/o Stoll SLC	FZ/FS/S	3618690	\$595
* able to couple under high pressure				



STOLL HYDRO-FIX – 6X COUPLING / DOES NOT CONNECT TO SLC		Type	Order No.	Price (excl. VAT)
	HYDRO-FIX cpl.	FZ/FS	3614720	\$1,405
	Plug plate (above)	FZ/FS	3618670	\$525
	Equip. for second tractor	FZ/FS	3617840	\$880

MULTI-COUPLER – FOR SPECIAL FENDT TRACTORS / VARIO		Type	Order No.	Price (excl. VAT)
	Multi-coupler cpl.	FZ/FS/S	3645240	\$1,210
	Plug plate (above)	FZ/FS/S	3645260	\$480
	Socket plate (below)	FZ/FS/S	3537390	\$730
* able to couple under high pressure				



MULTI-COUPLER – CARGO		Type	Order No.	Price (excl. VAT)
	Multi-coupler cpl. with integrated electrical plug	FZ/FS/S	3645250	\$1,210
	Plug plate (above)	FZ/FS/S	3645270	\$480
	Socket plate (below)	FZ/FS/S	3537400	\$730
* able to couple under high pressure				

STOLL TOOL-FIX – 2X COUPLING / FOR 3RD + 4TH CONTROL CIRCUITS		Type	Order No.	Price (excl. VAT)
	TOOL-FIX cpl.	FZ/FS	3331530	\$790
	Half boom end	FZ/FS	3474580	\$525
	Half attachment end	FZ/FS	3617080	\$265

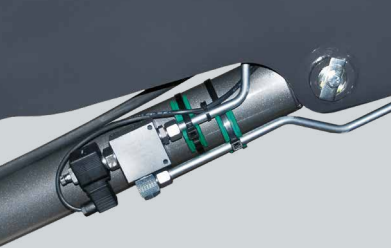
WORK QUICKLY, SAFELY AND COMFORTABLY. WITH STOLL ACCESSORIES.

3RD/4TH CONTROL CIRCUIT		Price (excl. VAT)
 <ul style="list-style-type: none"> ✓ Simple operation of hydraulic tools. ✓ No further special control device is needed. ✓ e.g. for silage forks, bale grabs or bale forks. 	Solid: simultaneous delivery 3rd control circuit	\$610
	ProfilLine Next Generation: simultaneous / subsequent delivery (individual price)	\$705
	Additional price for tool-fix (only FZ / FS, individual price)	\$790
HYDRO-LOCK		
 <ul style="list-style-type: none"> ✓ Functioning via double-acting hydraulic cylinder. ✓ Button-activated insertion and extraction of locking bolt. ✓ Attachment change without dismounting. 	Hydro-Lock FZ / FS	\$1,110
LOWERING SAFEGUARD		Price (excl. VAT)
 <ul style="list-style-type: none"> ✓ Sudden dropping of the loader is prevented. ✓ Required for manual work on the raised front loader if a person enters the loader's working zone. ✓ Fulfills the requirements of EN 12525/A1. ⚠ Does not meet the legal requirements with regard to work baskets. 	For ProfilLine Next Generation FZ / FS sizes 1 - 6 (see p. 18), all Solid and CompactLine models. (assembly kit, individual price)	\$1,360
	Additional equipment for both sides (assembly kit)	\$690

The Comfort Drive accessory function reduces impacts from loader and attachment – result: man and machine are treated with care. Thanks to technology!

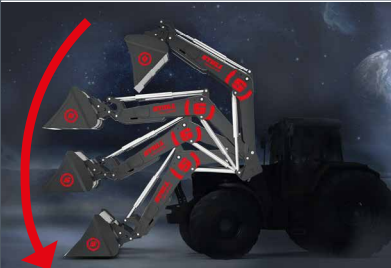
LOWERING RESTRICTOR		Price (excl. VAT)
	<ul style="list-style-type: none"> ✓ Built in throttle valves limit the lowering speed of the front loader. ✓ Stop-cocks on the attachment cylinders prevent pivoting motion (not included in assembly kit). ✓ Required with the deployment of working platforms. ⚠ For the transport of persons, an EC-type examination as defined by the EU directive on machinery (2006/42/EC) is mandatory. 	For ProfiLine Next Generation FZ / FS sizes 1 - 6 (see p. 18) (assembly kit, individual price) \$600
	Recommended both sides	
COMFORT-DRIVE		Price (excl. VAT)
	<ul style="list-style-type: none"> ✓ To smooth out the drive with an attached front loader. ✓ Hard impacts from uneven ground are cushioned. ✓ Driver and tractor are protected. 	1 Comfort-Drive FZ / FS \$915
		Additional cost for electrically (de)activated Comfort-Drive FZ / FS \$715
	2 Comfort-Drive Solid \$720	
RETURN TO LEVEL		Price (excl. VAT)
	<ul style="list-style-type: none"> ✓ Time savings and high loading performance through levelling automation. ✓ An attachment position, once set, can be replicated with the touch of a button. ✓ Operational with all Stoll single-lever control systems – no extra device needed. ✓ Additional rapid emptying function included. 	For ProfiLine FZ \$1,590

REAL³



- ✓ Third control circuit to control the attachments independently of the front loader controls.
- ✓ The attachment is directly fed from the tractor's hydraulic pump.
- ✓ Optimal use of attachments through simultaneous performance of their functions.

	Price (excl. VAT)
Lifting arm cable set equipment	\$1,140
Real3 rd Bowden cable valve	\$2,020
Real3 rd electrohydraulics valve	\$2,020
Real3 rd valve (retrofit in connection with tractor-own valves)	\$1,165
2 Hydro-fix + Retrofitting	\$525
4 Hydro-fix	\$1,020
6 Hydro-fix (only in connection with the tubing set)	\$1,390

SWITCH BOX



- ✓ Contains all switches for operation of the electrical functions of the front loader.
- ✓ Reduction of work time and assembly costs – all connections in one place.
- ✓ Available for all ProfiLine Next Generation front loaders.

	Price (excl. VAT)
For ProfiLine Next Generation FZ / FS (assembly kit)	\$315

CAMERA SYSTEM AND WORK LIGHTS



- ✓ For goal-oriented and exact work – the camera system and the work lights helps the driver see better.
- ✓ High comfort and improved efficiency when working with the attachment.

	Price (excl. VAT)
Camera system consisting of monitor, camera and cable set (incl. suction cup and holder)	\$1,365
Camera (individual price)	\$525
Monitor (individual price)	\$835
Work lights (only FZ)	\$1,270

WEAR SKIDS

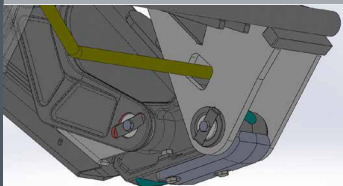

- ✓ The loader is protected in this area from wear caused by rough terrain.
- ✓ Can be retrofitted at any time thanks to protected screw connection.

	Price (excl. VAT)
Wear skid	\$180
ProfiLine Next Generation FZ 46	0 €
ProfiLine Next Generation FZ 48	0 €

Example
special painting.



COLOR EDITION. SPECIAL PAINTING.

PROFILINE FZ FRONT LOADER FOR TRACTORS WITH METALLIC PAINT!

Offer on request.

Best performance in terms of lifting power and height. Top values in stability and loading speed. Comfortable to operate: the ProfiLine Next Generation was specifically developed to fulfil all the needs of true professionals.

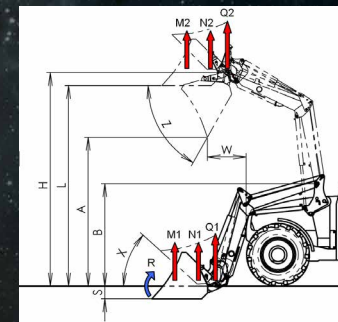

PROFILINE NEXT GENERATION				SIZE 1			SIZE 2				SIZE 3				SIZE 4				SIZE 5			SIZE 6				
mech. parallel linkage				FZ 36-20	FZ 36-24		FZ 39-23	FZ 39-27		FZ 39-31		FZ 41-25	FZ 41-29	FZ 41-33		FZ 43-27	FZ 43-30	FZ 43-34		FZ 46-26	FZ 46-29	FZ 46-33	FZ 48-33	FZ 48-37	FZ 48-42	
without parallel linkage					FS 36-24			FS 39-27			FS 39-31						FS 43-34									
Suitable for tractors with kW/hp			kW hp	40-75 50-100	50-75 70-100		45-95 60-130	60-95 80-130		65-95 90-130		60-120 80-160	75-120 100-160	80-120 110-160		75-130 100-180	85-130 110-180	95-130 130-180		95-190 130-260	105-190 140-260	120-190 160-260	140-220 190-300	150-220 200-300	155-220 210-300	
Lifting force in the implement's pivot point	below above	Q1 Q2	daN daN	2.020 1.490	2.370 1.750		2.300 1.550	2.670 1.800		3.070 2.060		2.510 1.680	2.880 1.930	3.280 2.200		2.660 1.890	3.060 2.120	3.420 2.430		2.580 2.020	2.940 2.280	3.320 2.590	3.320 2.230	3.730 2.500	4.150 2.790	
Lifting force (blade) 300 mm before the pivot point	below above	N1 N2	daN daN	2.020 1.490	2.370 1.750	2.020 1.470	2.300 1.550	2.670 1.800	2.300 1.500	3.070 2.060	2.640 1.730	2.510 1.680	2.880 1.930	3.280 2.200	2.840 1.870	2.660 1.890	3.060 2.120	3.420 2.430	30	2.580 2.020	2.940 2.280	3.320 2.590	3.320 2.230	3.730 2.500	4.150 2.790	
Lifting force (pallet) 800 mm before the pivot point	below above	M1 M2	daN daN	2.020 1.490	2.370 1.750	1.620 1.150	2.300 1.550	2.670 1.800	1.860 1.180	3.070 2.060	2.130 1.360	2.510 1.680	2.880 1.930	3.280 2.200	2.320 1.490	2.660 1.890	3.060 2.120	3.420 2.430	2.480 1.640	2.580 2.020	2.940 2.280	3.320 2.590	3.320 2.230	3.730 2.500	4.150 2.790	
Breakout force 800 mm before the pivot point	below	R	daN	2.620	2.890		2.910	3.550	3.080	3.550	3.080	2.900	3.540	3.850		3.540	4.580		3.840	4.560		4.140	4.900			
Maximum lift height in the implement's pivot point		H	mm	3.550			3.850				4.100				4.320				4.550			4.800				
Overloading height (H-210)		L	mm	3.340			3.640				3.890				4.110				4.340			4.590				
Dump height		A	mm	2.470			2.810				3.060				3.290				3.490			3.750				
Dump width		W	mm	710			700				790				780				800			880				
Digging depth		S	mm	210			210				210				210				210			210				
Pivot point of lifting arms		B	mm	1.680			1.800				1.945				1.945				2.045			2.180				
Tilt angle	below	X	° degree	41°			44°				44°				44°				44°			45°				
	rescooped	X1	° degree	55°	-	61°		-	61°	-	61°		-	61°		-	61°		-	63°		62°				
Dump angle	above	Z	° degree	62°			57°				57°				56°				58°			58°				
Pump output rate			l/min	60			75				90				100			120								
Stroke time			sec.	3,9	4,2		3,4	3,9		4,5		3,3	3,8	4,3		3,8	4,3	4,8		3,6	4,3	4,7	3,8	4,2	4,7	
Tilting time, implement			sec.	0,5	0,7	0,7	0,6	0,7	0,6	0,7	0,6	0,5	0,6	0,6	0,6	0,6	0,7	0,7	0,7	0,7	0,6	0,7	0,7	0,5	0,6	0,6
Dumping time, implement			sec.	1,3	1,6	2,4	1,3	1,6	2,2	1,6	2,2	1,1	1,3	1,4	2,1	1,3	1,7	1,7	2,3	1,3	1,6	1,6	1,2	1,4	1,4	
Weight, lifting arms without implement			kg	555	562	480	604	610	528	612	530	650	657	665	580	767	770	775	675	852	860	864	886	890	898	

The values given are averages. Depending on the type of tractor, these values may deviate up or down. Calculated at 195 bar hydraulic pressure!

Numbers become values. Our values for you are: tradition, quality and innovation.

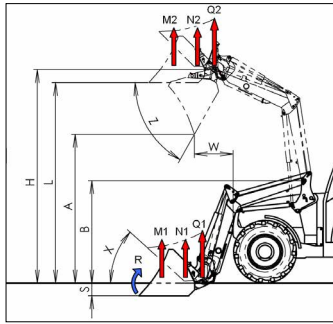

SOLID				28-14		30-16		35-18		38-20		40-22							
TYP				P	P	H	P	H	P	H	P								
Suitable for tractors with kW / horsepower			kW hp	29-44 40-60		35-50 45-65		40-60 55-80		50-80 65-100		60-100 80-135							
Lifting power l at attachment pivot point		lowered raised	Q1 Q2	daN	1.400 900		1.560 1.220		1.810 1.270		1.960 1.410		2.100 1.530						
Lifting power (bucket) 300mm in front of the pivot		lowered raised	N1 N2	daN	1.400 900		1.560 1.220		1.310 10		1.810 1.270		1.520 1.050		1.960 1.410		1.670 1.180		2.100 1.530
Lifting power (fork) 900 mm in front of pivot		lowered raised	M1 M2	daN	1.400 900		1.560 1.220		990 740		1.810 1.270		1.160 780		1.960 1.410		1.300 890		2.100 1.530
Breakout power 900 mm in front of pivot			R	daN	1.370		1.870		1.590		2.310		1.570		2.360		2.120		2.600
Max. Lift height at attachment pivot			H	mm	2.760		3.010		3.460		3.760		4.080						
Loading height			L	mm	2.550		2.800		3.250		3.550		3.870						
Dump height			A	mm	1.365		1.920		2.390		2.710		3.040						
Dump clearance			W	mm	550		600		650		700		785						
Digging depth			S	mm	210		210		210		210		210						
Boom pivot			B	mm	1.399		1.400		1.660		1.780		1.930						
Rollback angle		lowered	X	° degree	41		43		43		46		46						
Dump angle raised		raised	Z	° degree	72		63		63		58		58						
Pump performance				l/min.	50		50		50		50		60						
Raising time				sec.	3		4		4		5		5						
Rollback time, attachment			lowered	sec.	1,4		1,5		1,5		1,5		1,5						
Dump time, attachment			raised	sec.	1,6		1,7		1,7		1,7		1,7						
Weight, loader boom w/o attachment				kg	305		315		275		335		290		355		315		395

Values given are averages. Depending on tractor type, variations up and down will occur.

* Because of danger of rolling the tractor, front loader work can only be carried out with a suitable counter weight. Calculated with 195 bar hydraulic pressure!

- + MECHANICAL PARALLEL LIFT**
- + SAME DRIVE-IN SYSTEM AS PROFILINE NEXT GENERATION FRONT LOADERS**
- + OUTSTANDING TILT AND DUMP ANGLE**
- + LOW INHERENT WEIGHT**
- + IMPROVED PERFORMANCE DATA**
- + MODERN LOOK**
- + OPTIONAL: HYDRO-FIX UPPER PART, 3RD CONTROL CIRCUIT, 4TH CONTROL CIRCUIT AND COMFORT-DRIVE**
- + SPECIAL PAINT JOB (FOR AN EXTRA FEE)**

The FC 150, like its big brothers, has a Skid Steer frame for its attachment range. Flexibility and versatility are vital to us.

FC COMPACTLINE				FC 150	FC 250	FC 350	FC 450	FC 550
TYP				P	P	P	P	P
Suitable for tractors with kW / horsepower			kW hp	11-18 15-25	15-26 20-35	18-37 25-50	26-40 35-55	29-44 40-60
Tractor weight			kg	700-1.000	800-1.300	1.100-1.600	1.500-2.000	1.800-2.300
Lifting power I at attachment pivot point	lowered raised	Q1 Q2	daN	435 350	640 * 540	950 * 790	970 * 920	1.170 * 1.120
Lifting power (bucket) 300mm in front of the pivot	lowered raised	N1 N2	daN	390 310	570 480	850 710	870 820	1.050 1.010
Lifting power (fork) 700mm in front of pivot	lowered raised	M1 M2	daN	365 295	540 450	800 670	820 780	990 950
Breakout power 750 mm in front of pivot		R	daN	560	850	960	1.010	1.430
Max. Lift height at attachment pivot		H	mm	2.000	2.290	2.435	2.590	2.800
Loading height		L	mm	1.845	2.130	2.275	2.425	2.630
Dump height		A	mm	1.340	1.510	1.665	1.805	2.020
Dump clearance		W	mm	220	250	250	300	500
Digging depth		S	mm	75	85	105	110	120
Boom pivot		B	mm	998	1.196	1.196	1.216	1.276
Rollback angle	lowered	X	° degree	48	40	38	41	41
Dump angle raised	raised	Z	° degree	71	80	74	74	70
Pump performance			l/min.	15	20	25	30	40
Raising time			sec.	2,5	2,7	3,4	3,3	3,2
Rollback time, attachment	lowered		sec.	1,4	1,5	1,1	1,3	1,1
Dump time, attachment	raised		sec.	2,0	2,1	1,6	2,0	1,8
Weight, loader boom w/o attachment			kg	165	205	230	270	290

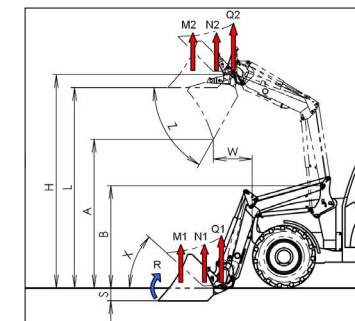

Values given are averages. Depending on tractor type, variations up and down will occur. The hydraulic pressure of the FC 150 = 140 bar, for all other FC front loaders 170 bar
 * Because of danger of rolling the tractor, front loader work can only be carried out with a suitable counter weight.



ALL BUCKETS IN FULL ACTION!

A TOUGH PERFORMER FOR YOUR PROFILINE NEXT GENERATION: THE PERFECT BUCKET FOR EVERY DEMAND, VERSATILE IN USE AND STRONG IN CONSTRUCTION:

- ✓ High level of robustness, low wear and low weight thanks to the use of high quality steel.
- ✓ Easy work even with sticky products – the conical shape, which opens up towards the cutting edge, makes this possible.
- ✓ The cutting edge can withstand the toughest stress – day after day, year after year.



Cutting edge hardness
BRINELL 500



Cutting edge hardness
BRINELL 500

ROBUST U.

For universal, light to moderate use.

Order no.	Width in m	Volume heaped in m ³	Volume level heap in m ³	Cutting edge Brinell Schneidkante	Weight in kg	Price (excl. VAT)
3428170	1,15	0,47	0,41	110 x 16	130	\$1,345
3428180	1,30	0,51	0,44	110 x 16	132	\$1,375
3428190	1,50	0,60	0,52	150 x 16	161	\$1,480
3428200	1,70	0,68	0,59	150 x 16	176	\$1,525
3428210	1,90	0,76	0,66	150 x 16	211	\$1,660
3428220	2,05	0,82	0,71	150 x 16	225	\$1,950
3428230	2,20	0,89	0,77	150 x 16	269	\$2,235
3461720	2,40	0,94	0,82	150 x 20	310	\$2,470

ROBUST M.

Specifically for the loading of loose bulk materials with low weight.

Order no.	Width in m	Volume heaped in m ³	Volume level heap in m ³	Cutting edge Brinell Schneidkante	Weight in kg	Price (excl. VAT)
3428330	2,05	1,45	1,13	150 x 16	320	\$3,075
3429920	2,20	1,56	1,22	150 x 16	384	\$3,255
3429930	2,40	1,70	1,33	200 x 20	432	\$3,615
3429940	2,60	1,86	1,45	200 x 20	462	\$3,700

Gripping legends and digging marvels. Our STOLL buckets get to grips with power, hand in hand with our ProfiLine Next Generation.



Cutting edge hardness
BRINELL 500

ROBUST S.

For working with heavy and sticky material, like wet earth or snow.

Order no.	Width in m	Volume heaped in m ³	Volume level heap in m ³	Cutting edge Brinell Schneidkante	Weight in kg		Price (excl. VAT)
3428260	1,50	0,60	0,52	150 x 16	172		\$1,965
3428270	1,70	0,68	0,59	150 x 16	190		\$2,130
3428280	1,90	0,74	0,64	150 x 20	242		\$2,350
3428290	2,05	0,81	0,70	150 x 20	258		\$2,905
3428300	2,20	0,87	0,76	150 x 20	308		\$3,045
3428310	2,40	0,94	0,82	200 x 20	351		\$3,340
3459310	2,60	1,01	0,88	200 x 20	376		\$4,170

ROBUST T.

With tines for earth moving and digging.



Cutting edge hardness
BRINELL 500

Order no.	Width in m	Volume heaped in m ³	Volume level heap in m ³	Cutting edge Brinell Schneidkante	Weight in kg	Tines	Price (excl. VAT)
3436990	1,50	0,60	0,52	150 x 16	177	5	\$2,245
3437000	1,70	0,68	0,59	150 x 16	190	6	\$2,455
3437010	1,90	0,74	0,64	150 x 20	242	6	\$2,710
3437020	2,05	0,81	0,70	150 x 20	258	7	\$3,300
3437030	2,20	0,87	0,76	150 x 20	308	7	\$3,480
3437040	2,40	0,94	0,82	200 x 20	351	8	\$3,750
3459300	2,60	1,01	0,88	200 x 20	376	8	\$4,485

MULTI-PURPOSE BUCKET HD.



Order no.	Width in m	Volumen in m ³	Opening width in mm	Weight in kg		Price (excl. VAT)
3668340	2,05	0,85	1.320	443		\$6,850
3668350	2,20	0,92	1.320	472		\$7,900
3668360	2,50	1,00	1.320	512		\$8,640
Side plate (details per set)						
3659430						\$435
Lateral teeth (details per set)						
3659420						\$330
3rd control circuit required						

BUCKET WITH GRAPPLE.

The universal implement for silage handling: thanks to the closed bottom, also wet and/or loose material can be handled.



Order no.	Width in m	Volumen in m ³	Opening width in mm	Weight in kg		Price (excl. VAT)
3547610	1,50	0,59	1.290	292		\$4,990
3547620	1,70	0,67	1.290	314		\$5,275
3547630	2,05	0,82	1.290	373		\$5,865
3547650	2,20	0,88	1.290	423		\$6,225
Side plate optional (details per unit)						
3548350						\$295
3rd control circuit required						

FORK WITH GRAPPLE.

Perfect to transport silage or manure.



Order no.	Width in m	Volume heaped in m ³	Tines bottom	Opening width in mm	Weight in kg		Price (excl. VAT)
3429090	1,30	0,54	7	1.300	226		\$4,660
3429100	1,50	0,63	8	1.300	249		\$5,050
3429110	1,70	0,71	9	1.300	268		\$5,410
3429120	2,05	0,87	11	1.300	304		\$6,030
3430650	2,40	1,02	13	1.300	355		\$6,525
3rd control circuit required							

SILAGE CUTTERS PROFI-CUT.

For taking portions of silage;
the serrated edge ensures a straight cut.



Order no.	Width in m	Volumen in m ³	Depth in mm	Opening width in mm	Number of tines	Weight in kg	Price (excl. VAT)
3334760	1,28	0,87	790	856	10	500	\$6,820
2449320	1,52	1,05	790	856	13	530	\$7,485
3306680	1,88	1,28	790	856	16	730	\$10,195
Shove off device							
3521560							\$390

3rd control circuit required | With width 1,88 two shove off devices required.

MANURE FORK.

For handling manure.
The arrangement of the tines prevents load loss.

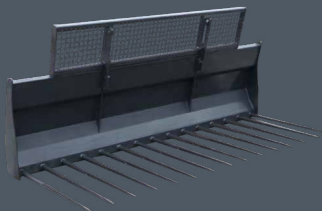

Order no.	Width in m	Opening width in mm	Number of tines	Weight in kg			Price (excl. VAT)
3364760	1,25	810	7	125			\$1,420
3364690	1,50	810	8	145			\$1,765
3364520	1,75	810	10	165			\$2,110
Lateral tine (details per set)							
3534780							\$235
3611820	2,00	810	11	243			\$2,845
3611830	2,00	1.100	11	264			\$3,175
3611930	2,25	1.100	12	288			\$4,230
3660460	2,50	1.100	14	318			\$4,540
Lateral tine (details per set)							
3534780							\$235
Loading grill (for forks from 2.00 m working width)							
3599680	2,00			40			\$495

Even wheel loaders are quaking in their boots.
Pros for the ProfiLine Next Generation.

BUCKET WITH GRAB.

Suitable for all kinds of silage:
ideal for direct loading and transportation.



Order no.	Width in m	Opening width in mm	Volumen in m ³	Weight in kg	Price (excl. VAT)
3687650	1,60	1.480	0,88	512	\$6,045
3687660	1,80	1.480	1,00	549	\$6,480
3687670	2,00	1.480	1,10	601	\$6,915
3687680	2,20	1.480	1,21	641	\$7,170
3687690	2,50	1.480	1,38	753	\$9,340
Corn tine optional (details per set)					
3635370					\$310
3rd control circuit required					

DISPOSER BUCKET.

Multi-functional implement, especially for bulky goods.



Order no.	Width in m	Opening width in mm	Volumen in m ³	Weight in kg	Price (excl. VAT)
3591550	1,80	1.480	1,00	557	\$5,385
3632970	2,00	1.480	1,10	605	\$5,760
3591560	2,20	1.480	1,21	636	\$5,995
3602920	2,50	1.480	1,38	762	\$7,780
Side plate wahlweise (details per set)					
3660080					\$700
3rd control circuit required					



Bale handlers by STOLL are the perfect choice for every size of bale.

TO THE BALES, GET SET, GO!

EVERY SUMMER IS HIGH SEASON FOR BALES – PREPARE YOURSELVES IN GOOD TIME: WITH STOLL BALE TOOLS.

Whether round or square bales, with foil or without: At STOLL you can always find the right tools.



WRAPPED BALE HANDLER H.

Perfectly suitable for foil wrapped round bales: there are no sharp edges that can damage the foil.

Order no.	Weight in kg						Price (excl. VAT)
2364610	225						\$4,320

For round bales Ø from 1,00 m to 1,80 m / for square bales Ø 1,60 m |
3rd control circuit required

WRAPPED BALE HANDLER-PRO H.

For the safe handling of round and square wrapped bales.

Order no.	Weight in kg						Price (excl. VAT)
3395020	305						\$5,395

Largest / smallest opening: 2,05 m / 0,65 m | Effective depth: 1,20 m | Transport width: 1,35 m | for square and round wrapped bales
3rd control circuit required

BALE CARRIER REAR.

For the transport of round and wrapped bales in the rear.

Order no.	Weight in kg						Price (excl. VAT)
3336750	115						\$1,210

Tractor rear three-point linkage or device triangle | Gripping area from 0,94 m to 1,34 m in 5 cm intervals / Lift arm boom length 1,28 m



BALE CARRIER REAR H.

Ideal for transporting round bales.

Order no.	Weight in kg						Price (excl. VAT)
3380410	105						\$1,405

For round bales | Gripping area from 0,82 m to 1,22 m / Beam length 1,28 m / Pipe diameter 0,16 m



MAXI BALE CLAW H.

Simultaneously grab, lift and load up to two bales.

Order no.	Weight in kg						Price (excl. VAT)
2449950	150						\$4,105

For round and square bales | **3rd control circuit required**



ROLL-TYPE BALE FORK.

Fits all bale types.

Order no.	Weight in kg						Price (excl. VAT)
3573240	245						\$3,295

For round and square wrapped bales / Gripping range from 0,60 m to 1,85 m | **3rd control circuit required**



BALE FORK LIFT H.

The built-in lifting device brings a height gain of up to 1,40 m.

Order no.	Weight in kg						Price (excl. VAT)
1339660	260						\$4,600

For round and square bales / lifting height gain of 1,40 m to the normal height | **3rd control circuit required**

Anyone can pile it on thick, but only a few are true to their word. Our pallet and bale forks are real experts in their field.



BALE SPIKE H.

Variable tine placing
– so the spike suits all bales.

Order no.	Lifting capacity in kg	Tine in mm	Weight in kg				Price (excl. VAT)
3378240		1x 800 / 1x 1.200	92				\$1,120
3411860		2 x 1.200	95				\$1,135
Frame							
3385190	1.000		76				\$775
Heavy duty tines (per unit)							
1330130		1.200	9				\$180
Heavy duty tines (per unit)							
0476240		800	5				\$165

For round and square bales | Additional tines can be retrofitted

BIG BALE FORK HS.

The distance between the tines can be easily changed.
Pallet fork tines can also be mounted onto these frames.

Order no.	Tine in mm	Weight in kg					Price (excl. VAT)
3684190	1.200	137					\$2,205
3684200	1.200 foldable	143					\$2,880
Frame HS							
3654340	-	110					\$1,125
Frame HS (details per unit)							
2400050	1.200	20					\$540
3331520	1.200 foldable	23					\$880

For round and square bales

BIG BALE FORK.

For safe transport of multiple stacked bales.

Order no.	Tine in mm	Weight in kg	Payload in kg				Price (excl. VAT)
3611920	1.200 foldable	147	1.000				\$1,855

For round and square bales. For safe empty driving on public roads, the bale tines can be folded upwards.

EVERY- THING ALRIGHT.

LIFTING, LOADING, STACKING – WITH STOLL PALLET FORKS FOR YOUR PROFILINE NEXT GENER- ATION YOU WILL ALWAYS WORK PRECISELY:

- ✔ These pallet forks are particularly sturdy because STOLL places a high value on robust construction and top-quality materials.
- ✔ You can position the tines exactly how you need them for your work. The tines can be moved by hand.
- ✔ The largest pallet fork lifts up to 3.5 t and belongs in the top class of front loader tools.

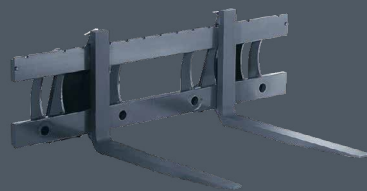
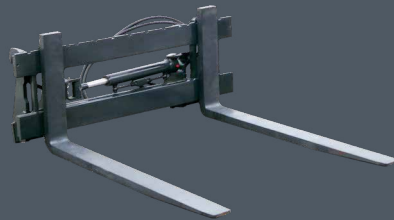
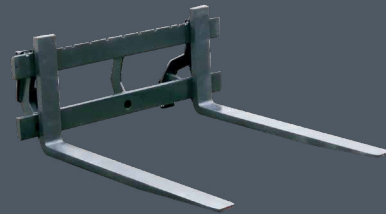

PALLET FORK HD.

The forks can be moved freely – the driver can also mount bale tines to the frame.

Order no.	Lifting capacity in kg	Tine in mm	Weight in kg	Width in mm	Connection	Price (excl. VAT)
3646850	2.500	1.200	196	1.250	ISO 2328	\$2,245
3654360	1.600	1.200	166	1.250	ISO 2328	\$2,055
3654370	1.600	1.000	158	1.250	ISO 2328	\$1,845
Frame HD						
3654340	2.500		94	1.250	ISO 2328	\$1,125
Pallet tine HD (details per unit)						
3570730	1.250	1.200	51		ISO 2A	\$555
3570720	800	1.200	36		ISO 2A	\$465
3570710	800	1.000	32		ISO 2A	\$360

Frame includes 3 bushes for bale tines

PALLET FORK HD WITH SIDE SHIFT.

Order no.	Lifting capacity in kg	Tine in mm	Weight in kg	Width in mm	Connection	Price (excl. VAT)
3614380	2.000	1.200	257	1.250	ISO 2328	\$4,720
Frame HD						
3666450	2.000		155	1.250	ISO 2328	\$3,600
Pallet tine HD (per unit)						
3570730	1.250	1.200	51		ISO 2A	\$555

Side shift +/- 145 mm | 3rd control circuit required

PALLET FORK HS 1500.

In addition to the pallet fork tines, as many as four bale tines can be mounted on the frame.

Order no.	Lifting capacity in kg	Tine in mm	Weight in kg	Width in mm	Connection	Price (excl. VAT)
3430830	1.600	1.000	185	1.500	ISO 2328	\$2,200
3434900	1.600	1.200	200	1.500	ISO 2328	\$2,425
Frame HS 1500						
3434840	1.600		115	1.500	ISO 2328	\$1,480
Pallet tine HS (details per unit)						
3570710	800	1.000	43		ISO 2A	\$360
3570720	800	1.200	66		ISO 2A	\$475

LIFTING- AIDS.

HEAVY LIFTING – LIGHT WORK.

The declared goal of our STOLL engineers is developing tools to make farming more efficient. With reduced manpower and robust technology you can manage your daily tasks much more easily. Your ProfiLine Next Generation will also feel the benefit.



Woodlands also need STOLL. We give you the best support in forestry operations. Because our your woodlands are worth it.

BIGBAG-LIFT.

Especially developed for bulk bags with one or two loops. The implement raises the load above the implement rotation point – so the view is guaranteed to be free.

Order no.	Payload in kg	Weight in kg	Lifting height above implement pivot point in mm				Price (excl. VAT)
3602900	1.000	115	1.500				\$2,145

For bulk bags up to 1,000 kg

BAG-LIFT H.

Perfect for bulk bags with four loops.

Order no.	Payload in kg	Weight in kg	Lifting height above implement pivot point in mm				Price (excl. VAT)
2357100	1.000	180	500				\$2,235

For bulk bags up to 1,000 kg

LOADING HOOK.

For good balance during transport: the load is centered near the front axle.

Order no.	Payload in kg	Weight in kg					Price (excl. VAT)
2309670	2.000	16					\$645

The hook is swivel mounted

IDEAL FOR TIMBER AND FORESTRY.

WOOD MAKING – STOLL FORESTRY IMPLEMENTS ENSURE EFFECTIVE WORK.

The log fork H and the log fork are specialists in forestry.



LOG FORK H WITH HYDRAULIC TOP-LOADING GRIP.

Gripping of logs with the top loading grip – so nothing is lost.

Order no.	Grip opening in m (clear width)	Weight in kg					Price (excl. VAT)
3390260	1,04	235					\$4,720
3rd control circuit required							



LOG FORK H.

For the transport and bunching of logs.

Order no.	Weight in kg						Price (excl. VAT)
1317750	150						\$2,410



TOP LOADING GRIP.

The ideal complement to the pallet fork, to retrieve or load logs.

Order no.	Opening width in mm	Weight in kg					Price (excl. VAT)
3548990	1.385	79					\$1,755
For pallet fork HD and HS 1500 (must be ordered separately) – 3rd control circuit required							

THE SMART EXTRA.



SAFETY GRILL.

So nothing slips: secures the load to the rear.

Order no.	Weight in kg						Price (excl. VAT)
3570550	23						\$450
For big bale fork HS and pallet fork HD – Does not fit for 1.500 mm frames							



14 DEG ADAPTER.

Thanks to the improved tilt angle everything stays inside the bucket.

Order no.	Weight in kg						Price (excl. VAT)
3522000	12						\$370
To improve the tipping angle (crowd) (set: 2 brackets incl. screws) – fits only for buckets and manure forks							



THREE-POINT-LINKAGE-ADAPTER.

For the rear-mounted hook implements.

Order no.	Weight in kg						Price (excl. VAT)
3386990	60						\$760
For hook implements in 3 point rear mounting, lifting capacity 1,5 t at the coupling point of the lower linkage							



CONVERSION KIT TO HOOK IMPLEMENTS.

For the conversion of hook implements to Euro standard.

Order no.	Weight in kg			Price (excl. VAT)
1334090	19			\$465
1 Conversion Kit (left + right)				



HOOKS AND EYES.

The individual set for conversion to hook implements.

Order no.	Weight in kg			Price (excl. VAT)
3320080				\$220
Loose set: 2 hooks, 2 eyes				



IMPLEMENT STAND.

Everything tidy: the ideal storage space for up to four implements.

Order no.	Width in m	Height in m	Weight in kg	Price (excl. VAT)
3523120	1,22	2,40	150	\$1,855
Delivery without implements.				

ADAPTER / QUICK-CHANGE FRAME.

Order no.	Weight in kg			Price (excl. VAT)
3664360	70			\$1,345
Adapter Euro to Tenias				
3551060	44			\$1,255
Adapter Euro to Faucheux				
3733790	78			\$675
MX tool adapter for Euro quick-change frame mechanical locking device				
Option:				
Skid Steer quick-change frame				
Euro quick-change frame				
Euro + Alö quick-change frame				
Euro +SMS quick-change frame				

STOLL thinks globally and liberally. That's why, in our range, you will also find smart special solutions for ProfiLine Next Generation, if that's what your life requires. STOLL supports you all the time.

EVERY TOOL FITS – EVEN THOSE BY OTHER MANUFACTURERS.

- ✓ Our customers can attach all tools with a Euro attachment to STOLL front loaders in the ProfiLine Next Generation series and the Solid.
- ✓ Even coupling systems from other manufacturers fit with these front loaders – with our combi-change frame.



Tenias adapter



Euro



MX tool adapter for Euro quick-change frame



Euro + Alö



Skid Steer



Euro + SMS

CLASSIC ALL-ROUNDER.

THE SOLID STANDS OUT FOR ITS FLEXIBLE USAGE POSSIBILITIES: EVERYTHING IN THE USUAL TOP STOLL QUALITY WITH AN EXCEPTIONAL PRICE/PERFORMANCE RATIO. HERE YOU WILL FIND THE EXTENSIVE TOOL RANGE THAT FITS THE SOLID.

- ✓ Easy to handle
- ✓ Flexible implementation
- ✓ Long working life

PALLET FORK.

Pallet loading made easy. Thanks to its sturdy construction, you can pick up to 1.000 kg at a time with the pallet fork. Adjust the spacing of the pallet tines to suit your needs.



Order no.	Lifting capacity in kg	Tine in mm	Weight in kg	Width in mm	Connection		Price (excl. VAT)
Pallet fork							
3567980	1.000	1.000	113	1.200	ISO 2328		\$1,435
Frame							
3567990	1.000	-	59	1.200	ISO 2328		\$750
Pallet tine (per unit)							
3570700	500	1.000	27		ISO 1A		\$345

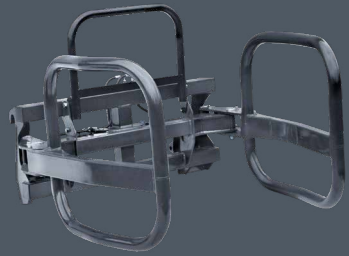

WRAPPED BALE HANDLER.

So your wrapped bales remain undamaged. The wrapped bale tongs have no sharp edges and have been developed specifically for the transportation and loading of wrapped bales.

Order no.	Opening width in mm (largest/smallest)	Weight in kg					Price (excl. VAT)
3714810	1.400/800	114					\$3,495
For round bales ϕ from 0,80 m to 1,40 m, 3rd control circuit required							

The superheroes of tools. Steeled for every challenge, these tools stand their ground. Reliable and powerful.

BALE SPIKE.

A spike for all bales. Transport round and square bales easily and safely with the bale spike. The tines can be placed in four positions in the frame, depending on the application.

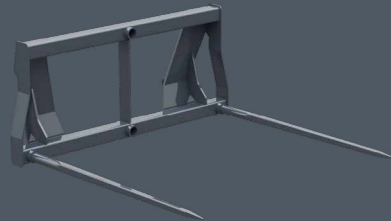

Order no.	Lifting capacity in kg	Tine in mm	Weight in kg				Price (excl. VAT)
3611810	700	2 x 800	68				\$945
3608420	700	2 x 1.200	76				\$975
Frame							
3608430			58				\$615
Tine							
0476240		800	5				\$165
Tine							
1330130		1.200	9				\$180

The bale spike has been developed for the handling of round and square bales.

UNIVERSAL BUCKET.

Ideal for light to moderate use. Your loose bulk material can also be easily loaded.



Order no.	Width in m	Volume heaped in m ³	Volume level heap in m ³	Weight in kg			Price (excl. VAT)
3550490	1,40	0,45	0,36	99			\$1,065
3550500	1,60	0,52	0,41	109			\$1,165
3550510	1,85	0,61	0,48	131			\$1,360
3550520	2,10	0,70	0,55	171			\$1,605



COMPACT LOADERS.

**IDEAL FOR ALL TASKS – THE EXTENSIVE
COMPACTLINE TOOL RANGE REMAIN
IMPRESSIVE IN TIGHT SITUATIONS.**

- ✓ Shovelling, grabbing or loading – STOLL tools offer the right solution for all tasks. Round about the house and farmyard, forest, garden and landscaping!
- ✓ For the driver to have unobstructed sight of the working zone, all tools have a Skid Steer attachment.
- ✓ Even the small ones have great power: the light and compact construction of these tools fits perfectly with the CompactLine.

The sandpit's over. Our CompactLine buckets load, shovel and grab like the big boys.

BUCKET.

For all loading work.



Order no.	Width in m	Height in m	Depth in m	Volume level heap in m ³	Volume heaped in m ³	Weight in kg	Price (excl. VAT)
3634460	1,22*	0,45	0,46	0,15	0,17	70	\$1,125
3533440	1,22	0,57	0,60	0,18	0,21	100	\$1,170
3495570	1,40	0,57	0,60	0,21	0,24	108	\$1,455
3478580	1,57	0,57	0,60	0,27	0,31	118	\$1,645
3478590	1,74	0,57	0,60	0,30	0,35	130	\$1,825

* for CompactLine FC 150 P

BUCKET WITH GRAPPLE.

The universal gripper, because thanks to the closed bottom, wet and/or loose material can also be transported.



Order no.	Width in m	Height in m	Depth in m	Opening in mm	Weight in kg		Price (excl. VAT)
3535300	1,20	0,67	0,60	950	115		\$3,090
3535310	1,45	0,67	0,60	950	130		\$3,330

3rd control circuit required

Whether it's bale-handling, pallet loading, log moving or other tasks, compact STOLL tools are all-rounders. They work daily to stand up to tricky, highly diverse tasks.

FORK WITH GRAPPLE.

Ideal to retrieve and load manure, compost, shrubs and silage.



Order no.	Width in m	Height in m	Depth in m	Opening width in mm	Weight in kg		Price (excl. VAT)
3535320	1,20	0,69	0,61	950	120		\$3,610
3535330	1,45	0,69	0,61	950	135		\$3,865

3rd control circuit required

GRIP FORK.

A must in forestry and landscape maintenance: With the strong tines it grabs bulky tree trunks and branches.

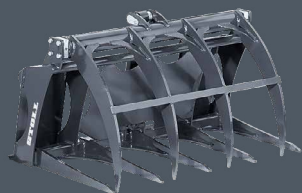

Order no.	Width in m	Opening width in mm	Weight in kg				Price (excl. VAT)
3508220	1,15	870	130				\$2,770

3rd control circuit required

MANURE FORK.

For loading of farmyard manure and compost.



Order no.	Width in m	Height in m	Depth in m	Weight in kg			Price (excl. VAT)
3509620	1,21	0,56	0,67	68			\$1,600
3535290	1,45	0,56	0,67	79			\$1,795



BALE TINE.

Compact bale handling in narrow courtyards or stables.

Order no.	Tine in mm	Weight in kg	Lifting capacity in kg				Price (excl. VAT)
3486330	800	60	1.000				\$1,425
Frame							
3486100	-	36	-				\$790
Bale tine (per unit)							
3486320	800	12	500				\$315
Optional pallet tine (per unit)							
3486290	800	12	500				\$315

PALLET FORK.

The classic to load pallets.



Order no.	Lifting capacity in kg	Tine in mm	Weight in kg				Price (excl. VAT)
3486070	1.000	800	60				\$1,425
3733280	1.000	1.000	113				\$1,425
Frame							
3486100	-	-	36				\$790
3733290	-	-	59				\$790
Bale tine (per unit)							
3486290	500	800	12				\$315
3570700	500	1.000	27				\$315
Optional pallet tine (per unit)							
3486320	500	800	12				\$315

TOP LOADING GRIP.

The ideal complement to the pallet fork, to retrieve or load logs.



Order no.	Opening width in mm	Weight in kg					Price (excl. VAT)
3520780	870	40					\$1,105

For CompactLine pallet fork (has to be ordered separately) | **3rd control circuit required**



LOG GRAPPLE.

Grab and load logs individually.

Order no.	Width in m	Opening width in mm (max.)	Weight in kg				Price (excl. VAT)
3556810	0,29	750	115				\$3,370
Log grapple without boom (can be combined with boom of shovel)							
3611140							\$2,505
Rotator optional							
3601520							\$2,980
3rd control circuit required							



SHOVEL.

Dig narrow, deep trenches – up to 1,16 m below ground level.

Order no.	Width in m	Working depth below ground (m)	Swivel angle	Weight in kg			Price (excl. VAT)
3557480	0,30	1,16	118°	105			\$2,245
Digging shovel without boom (can be combined with arm of log grapple)							
3611160							\$1,405
Boom Ditching shovel							
3599580	0,80						\$1,125
3rd control circuit required							



THREE-POINT-ADAPTER.

For the rear mounting of implements for CompactLine onto tractors.

Order no.	Payload in kg	Weight in kg					Price (excl. VAT)
3601100	500	38					\$1,045

Looking for an implement to compliment your other brand of loader? We are here to help. That's exactly why we have constructed adapter frames for the CompactLine that allow you to complete your tractor and a previously owned loader from a different brand with our tools.



ATTACHMENT FRAME EURO-SKID.

Mount implements with Euro-connection onto a Skid Steer attachment frame.

Order no.	Weight in kg				Price (excl. VAT)
3547310	23,5				\$825



IMPLEMENT ADAPTER FOR JOHN DEERE COMPACT FRONT LOADER.

Real STOLL quality on John Deere compact loaders.

Order no.	Weight in kg				Price (excl. VAT)
3571680	30				\$895

RECOMMENDED TOOL WIDTH.

Width	FZ 36-20 FZ 36-24 FS 36-24	FZ 39-23	FZ 39-27 FZ 39-31 FS 39-27 FS 39-31	FZ 41-25	FZ 41-29	FZ 41-33 FS 41-33	FZ 43-27 FZ 43-30 FZ 43-34 FS 43-34	FZ 46-26 FZ 46-29 FZ 46-33	FZ 48-33 FZ 48-37 FZ 48-42	Solid 28-14 P	Solid 30-16 P/H	Solid 35-18 P/H	Solid 38-20 P/H	Solid 40-22 P
Robust U - Universal bucket														
1,15 m	•									•	•	•		
1,30 m	•	•	•							•	•	•	•	
1,50 m	•	•	•								•	•	•	
1,70 m		•	•	•	•	•							•	•
1,90 m		•	•	•	•	•							•	•
2,05 m				•	•	•								•
2,20 m				•	•	•	•							
2,40 m						•	•	•	•					
Robust M - Maxi-bulk buckets														
2,05 m				•	•	•	•	•	•					
2,20 m				•	•	•	•	•	•					
2,40 m						•	•	•	•					
2,60 m							•	•	•					
Robust S / T - heavy duty series														
1,50 m		•	•	•	•	•							•	•
1,70 m		•	•	•	•	•	•	•	•				•	•
1,90 m				•	•	•	•	•	•					•
2,05 m				•	•	•	•	•	•					
2,20 m				•	•	•	•	•	•					
2,40 m						•	•	•	•					
2,60 m							•	•	•					

Width	FZ 36-20 FZ 36-24 FS 36-24	FZ 39-23	FZ 39-27 FZ 39-31 FS 39-27 FS 39-31	FZ 41-25	FZ 41-29	FZ 41-33 FS 41-33	FZ 43-27 FZ 43-30 FZ 43-34 FS 43-34	FZ 46-26 FZ 46-29 FZ 46-33	FZ 48-33 FZ 48-37 FZ 48-42	Solid 28-14 P	Solid 30-16 P/H	Solid 35-18 P/H	Solid 38-20 P/H	Solid 40-22 P
Manure Forks														
1,25 m / 7 tines 0,81m lg.	•	•	•	•	•						•	•	•	
1,50 m / 8 tines 0,81m lg.		•	•	•	•	•							•	•
1,75 m / 8 tines 0,81m lg.		•	•	•	•	•	•	•	•					•
2,00 m / 11 tines 0,81m lg.					•	•	•	•	•					
2,00 m / 11 tines 1,1m lg.							•	•	•					
2,25 m / 12 tines 1,1m lg.							•	•	•					
2,50 m / 14 tines 1,1m lg.								•	•					
Bucket with grab / Disposer shovel														
1,60 m*	•	•	•	•	•	•	•	•	•					
1,80 m		•	•	•	•	•	•	•	•					
2,00 m			•	•	•	•	•	•	•					
2,20 m				•	•	•	•	•	•					
2,50 m								•	•					
Multi-purpose bucket HD														
2,05 m		•	•	•	•	•	•	•	•				•	•
2,20 m				•	•	•	•	•	•					
2,50 m						•	•	•	•					
Bucket with grapple														
1,50 m	•	•	•								•	•	•	
1,70 m		•	•	•	•	•						•	•	
2,05 m		•	•	•	•	•	•						•	
2,20 m				•	•	•	•							

* Bucket with grab / Disposer shovel 1,60 m: Does not fit on broad beams

OUR COMPETENT TEAM WORLDWIDE.

SALES MANAGEMENT.

Sales Director Central Europe



Markus Jankowski

Phone: 05344 20-126

Fax: 05344 20-182

Mobile: 0171 5660251

E-Mail: mj@stoll-germany.com

Head of Sales International



Torben Meyer

Phone: +49 (0) 5344 120-251

Fax: +49 (0) 5344 20-182

Mobile: +49 (0) 171 / 2 27 13 91

E-Mail: tm@stoll-germany.com

Area Sales Manager Nordic



Peter Korning Ove

Mobile: +45 40 17 27 39

E-Mail: po@stoll-germany.com

Area Sales Manager Sweden



Christian Ystriim

Mobile: +46 70 88 03 143

E-Mail: cy@stoll-germany.com

Sales Compact Loader



Michael Schreiber

Phone: 05344 20-118

Fax: 05344 20-49118

E-Mail: msc@stoll-germany.com

Area Sales Manager South East Europe



Serhiy Hryn'

Phone: +49 (0) 5344 20-122

Fax: +49 (0) 5344 20-182

Mobile: +49 170 / 6 38 56 04

E-Mail: shr@stoll-germany.com

GENERAL.

TERMS OF PAYMENT:

All deliveries are always made in accordance with our terms and conditions of sale and delivery. The prices stated are intended for trade and commerce. The price information and technical specifications are non-binding. It is possible that both prices and technical specifications have changed in the meantime or that other prices or technical specifications apply in individual cases due to special circumstances. To obtain a binding offer, please contact us.

With the publication of this price list, all previous prices lose their validity. Non-binding prices in net ex works excluding packaging.

Subject to change without notice. Illustrations partly with optional equipment. Front loaders must always be parked with a suitable tool. This has been omitted from some illustrations for reasons of presentation. The STOLL accessories and the components offered are intended exclusively for the purpose of intended operation with STOLL front loaders.



APPLICATION AREAS. SUITABLE FOR ALL REQUIREMENTS.

FIELD



FARM



FOREST



COMMUNITY



SOLID



PROFILINE
NEXT
GENERATION



COMPACTLINE

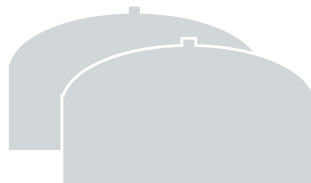

BIOGAS



LIVESTOCK



WINE AND FRUIT
GROWING



GARDEN



HOME OF QUALITY.



Wilhelm STOLL Maschinenfabrik GmbH
Bahnhofstr. 21 | 38268 Lengede
Telefon: +49 (0) 53 44 / 20-222
Fax: +49 (0) 53 44 / 20-49182

www.stoll-germany.com